

MIT OpenCourseWare
<http://ocw.mit.edu>

6.033 Computer System Engineering
Spring 2009

For information about citing these materials or our Terms of Use, visit: <http://ocw.mit.edu/terms>.

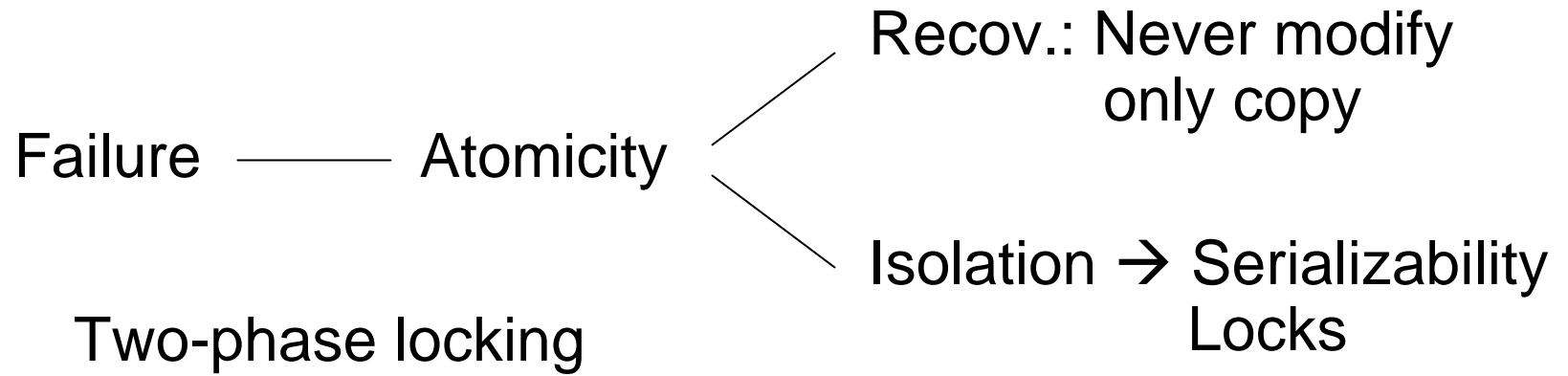

Deadlocks

{
read x
write y

comput'n
COMMIT()

acq l_x
read x

acq l_y
read y

→ acq l_y
W y

→ acq l_x
W x

- 1) Timers
- 2) Waits for graph

Logs & Locks

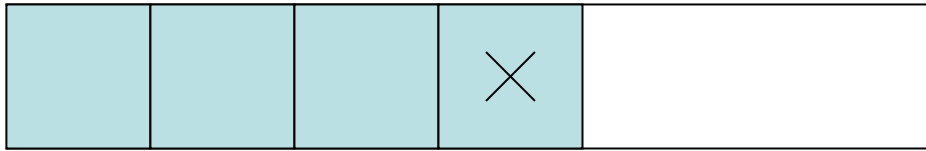

Applications

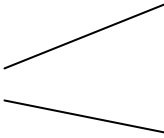
- 1) Transactions 
 - Consistency
 - Durability
- 2) Multi-site atomicity

Transactions

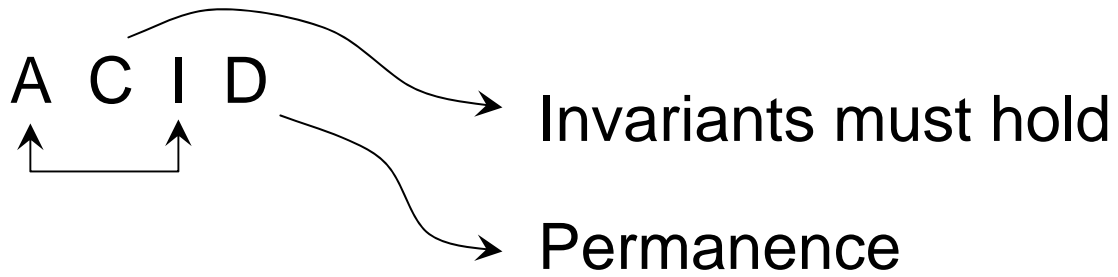

Centralized

Integrity rules

SID	Name	DeptID
35	----	43

Dept ID	Dept name
43	
25	

Distributed Data

- DNS → Expiration time
- Web caches
 - ↳ “if-modified-since”

Strong cons:

Read returns result
of last write

Eventual consistency

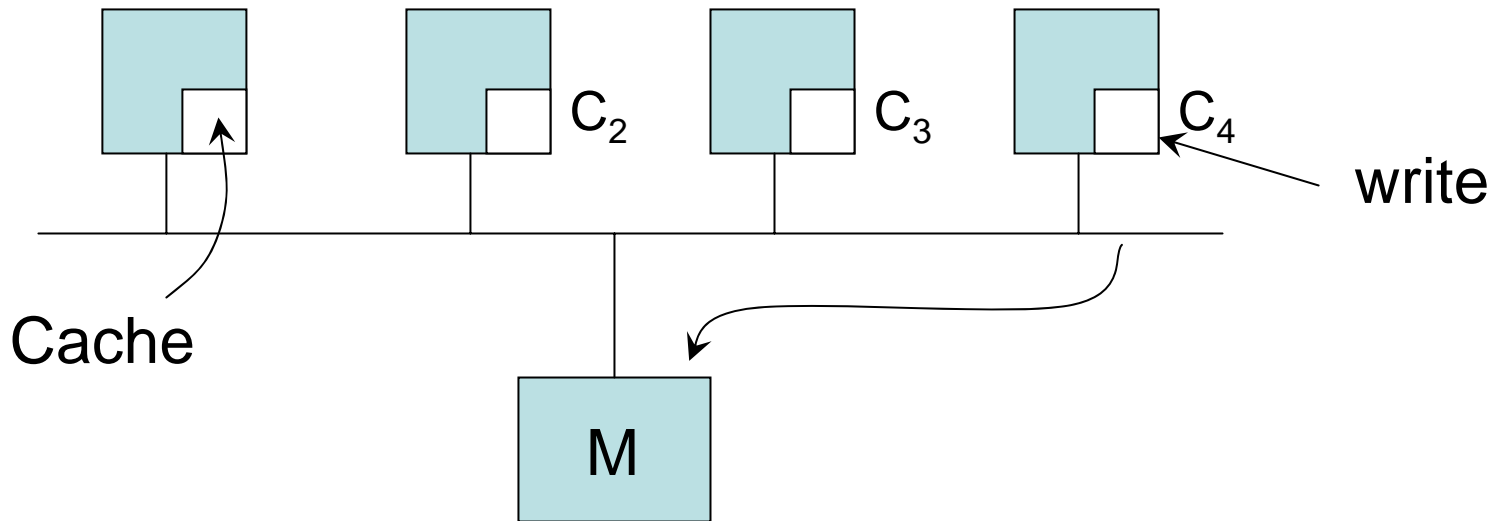

- 1) Write-thru cache
- 2) Snoopy cache